



FA1.2LT (x2)
Bucket technical characteristics

Dimensions

D1: 131 mm

D2: 105 mm

H: 135 mm *without the lid*

Deviation ±1mm

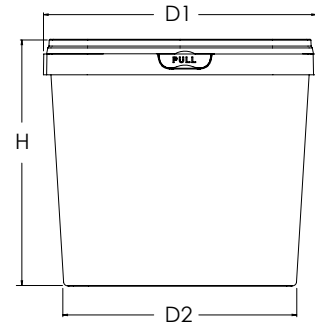

Other elements

Capacity (LT)	Volume to rim 1.000 LT	Brim full volume 1.200 LT
Net weight / Deviation (±2.5%)	47 gr	
Buckets packaging	Carton 320 pcs	
Decoration	IML Label 350,88X110,78 mm	
Packaging	5 Vertically	

Lid technical characteristics

FA1.2LT (x2)

Dimensions

D: 127 mm

H: 9.6 mm

Deviation ±1mm

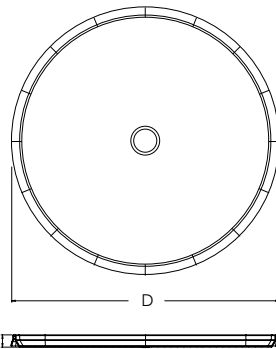

Lid technical characteristics

FA1.2LT FOIL

Dimensions

D: 128 mm

H: 14.5 mm

Deviation ±1mm



Other elements

Lid weight (gr) Deviation (±2.5%)	11 gr (FA 1.2LT (x2))	12 gr (FA 1.2LT FOIL)
Lid packaging	Carton 1.500 pcs	Carton 1.400 pcs ή 1500 pcs
Decoration	IML Label Ø 108 mm	IML Label Ø 108 mm

USEFUL STORAGE INFORMATION: To preserve the quality of this product, it is recommended that it be stored in its original packaging, away from any source of local heat and moisture, away from direct sunlight (below 30°C) and dry conditions. It is recommended that the product be allowed to reach operating temperature 24 hours before use.

RAW MATERIAL: Polypropylene (PP)

